

HA20 E HA20 E PRO



BOOST YOUR PRODUCTIVITY

- > Oscillating axle and 4-wheel steering for more agility (PRO model)
- > Haulotte Extra Reach : additional load and tilt capacity up to 350 kg and 6° (optional)

OPERATE ANYTIME ANYWHERE WITH ZERO EMISSION

- > Full electric drive
- > Silent and clean operations
- > Versatile use: indoor / outdoor on all types of worksites

EXTEND YOUR DUTY CYCLES

- > More than one day of assured duty cycle in complete electric mode
- > Multiple and fast charging solutions adapted to all worksite situations
- > Fast charging thanks to removable Range Extender (option compatible with other PULSE0 machines)

WORK SAFELY

- > Haulotte Activ'Shield Bar: anti-crushing system (standard on PRO model)
- > Haulotte Activ'Lighting System: load and unload the machine in low visibility conditions (standard on PRO model)
- > Transport handle to ensure the operator is safe while loading and unloading (optional)

HA20 E HA20 E PRO

ARTICULATING BOOMS ELECTRIC

TECHNICAL DATA

	HA20 E	HA20 E PRO
Working height	20.5 m	
Platform height	18.5 m	
Horizontal outreach	11.9 m	
Up and over clearance	8.5 m	
Lift capacity	250 kg - option 350 kg	
A Length	8.6 m	
B Width	2.43 m	
C Height	2.47 m	
D Wheelbase	2.5 m	
E Ground clearance	30 cm	
F x G Platform size	1.8 x 0.8 m (Option 2.40 x 0.9 m)	
H Storage / transport length	6.16 m	
I Storage / transport height	2,98 m	
Tailswing	42 cm	
Tilt	4° - option 6°	
Proportional drive speed	0.5 - 5 km/h	
Maximum wind speed rating	45 km/h	
Gradeability	40 %	
Turning radius - outside	5,2 m	3.7 m
Weight	9 790 kg	9 940 kg
Batteries	72 V - 390 Ah (C20)	

Some options increase the machine weight.

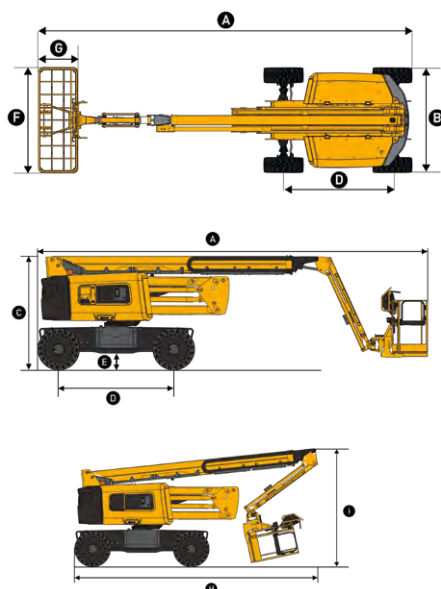

STANDARD EQUIPMENT

- > Haulotte Activ'Screen
- > Haulotte Activ'Shield Bar (standard PRO model)
- > Haulotte Activ'Lighting System (standard PRO model)
- > Haulotte Activ'Energy Management: smart system
- > AGM battery pack 72V - 390Ah
- > Modular basket 1.8 x 0.8 m
- > Proportional and simultaneous movements
- > Front oscillating axle (standard PRO model)
- > 4-wheel drive and 2-wheel steering (standard E model)
- > 4-wheel drive and 4-wheel steering (standard PRO model)
- > 355° non-continuous rotation
- > Drive orientation assist
- > Flashing light
- > Universal telematic plug
- > Range Extender protective cover

OPTIONS & ACCESSORIES

- > Haulotte Extra Reach
- > FASTN, universal and active anchorage
- > REX 5.2 kW - Stage 5 (+ 250 kg)
- > Accelerated charger 380V
- > Lithium-Ion maintenance-free batteries
- > Transport handle
- > Large basket 2.44 x 0.91 m
- > Swing door entry gate
- > Working light
- > Glazier kit
- > Pipe cradle
- > USB plug
- > 360° continuous rotation (optional on PRO model only)
- > Non-marking tires
- > Shipyard package
- > Cold weather package
- > Biodegradable hydraulic oil
- > Circuit breaker
- > Sheralp telematics subscription
- > User drive assist

